

ITEM	PART NO.	PART NAME	QTY
1	PAC-10421	CUSHION FRAME ASM - STATIC	1
2	WAV-50218	SUSPENSION MAT	1
3	90912	CLIP - WIRE MAT RETENSION	4
4	WAV-50216	SPRING	4
5	PAC-11148	BOLT - M8 X 20	4
6	90885	BOLT - M10 X 25	4
7		BAG - FASTENERS	1
8		BOX	1

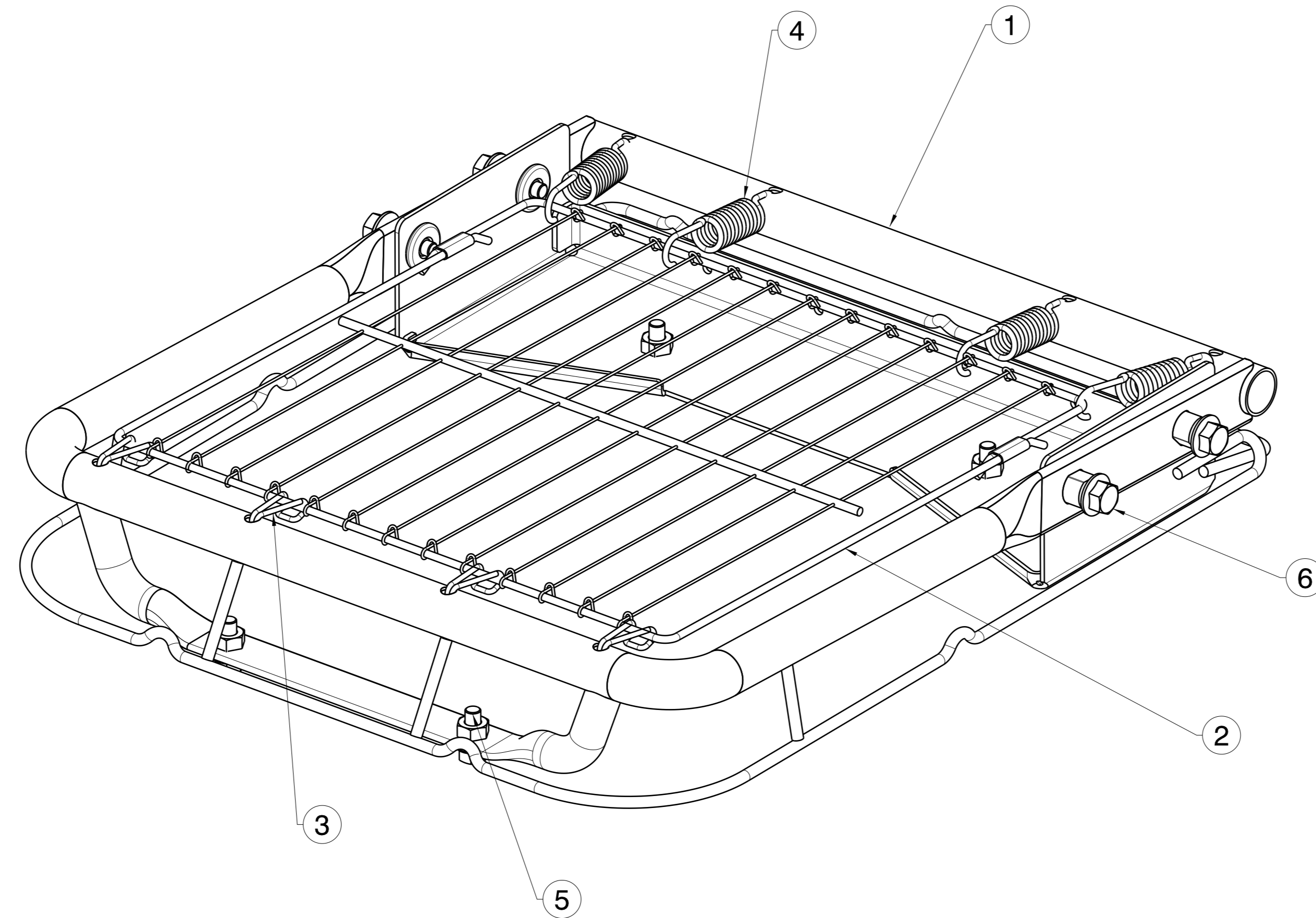

7216	AA	RELEASED FOR SERVICE	27JUL12	INT	**	**
FRAME	CHG NO.	LET	REVISION	DATE	DRW	CHK
UNLESS OTHERWISE SPECIFIED DRAWING TOLERANCES ARE			DIMENSIONING & TOLERANCING PER ASME Y14.5 M-1994			
LINEAR		ANGULAR	LAST VIEW	3RD ANGLE PROJECTION		
ONE PLACE ± X.X	TWO PLACE ± X.XX	ONE PLACE ± X.X ° TWO PLACE ± X.XX °	LAST SECT	COMPUTER GENERATED GRAPHICS		
- DO NOT SCALE THIS DRAWING -			FILE NO. SEE PART BLOCK			
DRAWN BY	DATE	CHECKED	APPROVED	THIS DRAWING IS COPYRIGHTED AND REMAINS THE EXCLUSIVE PROPERTY OF GRAMMAG TRUCK INTERIOR SYSTEMS, INC. UNAUTHORIZED COPYING, REPRODUCTION OR OTHER USE IS PROHIBITED AND WILL BE PROSECUTED.		
INTENT	08MAY12	**	**	UNLESS OTHERWISE SPECIFIED DIMENSIONS ARE IN MM		
MATERIAL					SCALE 1:2	
NAME CUSHION FRAME ASM - STATIC SERVICE KIT			NO PAC-SP11421-DWG			

PAC-SP11421-DWG
UNCONTROLLED